

GVM - 7500kg
GCM - 9000kg
WHEELBASE - 3400mm

ISUZU 4HJ1 ENGINE PERFORMANCE

- Type: 4 Cylinder, in line, OHC, direct injection, four stroke, diesel
- Bore x Stroke: 115 x 110 mm
- Displacement: 4,985 cc
- Compression Ratio: 18.5 : 1
- Power Output (ISO): 150 PS @ 3,100 rpm
- Torque (ISO): 363Nm @ 1,600 rpm

DIMENSIONS AND WEIGHTS

- Estimated Kerb Mass (kg):

Front	1,725
Rear	925
Total	2,650
- Frame Width: 750 mm
- Turning Circle (m) (kerb to kerb): 14.4
- Ground Clearance (min): 225 mm

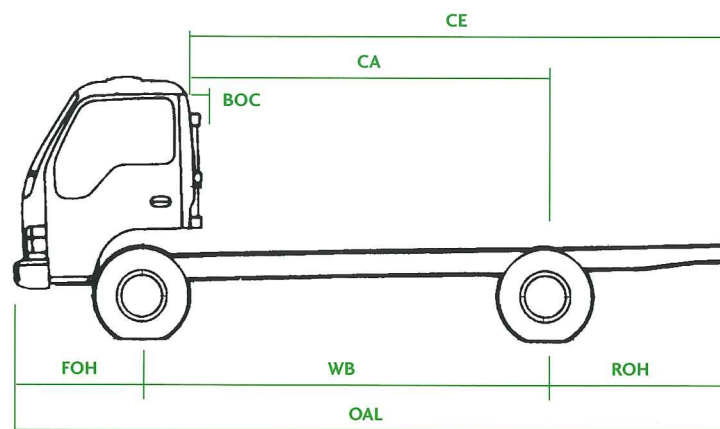

TRANSMISSION

- Isuzu MXA5R - 5 speed overdrive with synchromesh on all gears, with 2 ratio 4WD transfer case

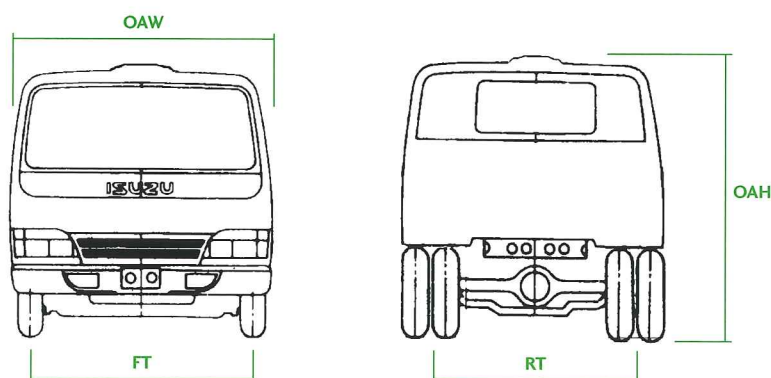

Wheelbase (WB)	3,400mm	Front overhang (FOH)	1,060mm
Cab to rear axle (CA)	2,760mm	Rear overhang (ROH)	1,620mm
Overall width (OAW)	1,995mm	Cab to rear of frame (CE)	4,380mm
Overall length (OAL)	6,080mm	Overall height (OAH)	2,515mm
Front Track (FT)	1,665mm	Back of cab/clearance (BOC)	95mm
Rear Track (RT)	1,525mm		

NPS 450

TRUCK 4x4

ISUZU

RELIABILITY IS EVERYTHING

ENGINE - ISUZU 4HJ1

Lubrication:

- Pressure feed lubrication with full flow paper element and partial flow sub filter
- Sump capacity: 8.3 litres including filter

Cooling System:

- Water cooled system thermostatically controlled with pressure vented heavy duty radiator
- V-Belt driven water pump with 475 mm diameter, 8 bladed, viscous hub, clutch controlled fan
- Coolant capacity: 12 litres

FUEL SYSTEM

- 'Zexel' in-line fuel injection pump with 'Bosch' 4 hole injectors
- Mechanical fuel pump
- Paper element air cleaner with raised vertical air intake
- Fuel tank capacity: 100 litres

CLUTCH

- Hydraulic control, dry, single plate, with diaphragm spring, asbestos free clutch plate 300 mm diameter
- Lining area: 847 sq cm (both sides)
- Auto adjusting clutch cylinder

TRANSMISSION - ISUZU MXA5R

- 5 speed overdrive, synchromesh with floor mounted short-throw gear shift & remote linkage to gearbox

Gear ratios:1	
1st	4.987
2nd	2.870
3rd	1.594
4th	1.000
5th	0.728
Reverse	4.774

- Oil capacity: 3.2 litres
- Reverse warning buzzer
- Electrically switched 4WD selection
- Column shift: high/low selection control
- Transfer case ratio: High 1.00:1, Low 1.868:1
- Transfer case oil capacity: 1.7 litres
- Power take-off provision on left hand side
- Maximum geared speed on standard tyres: 101 km/hour
- Calculated maximum rolling gradeability at manufacturer's GVM = 63%, GCM = 52%

REAR AXLE - CAPACITY 5,000 KG

- Isuzu heavy duty fully floating banjo type with hypoid single speed reduction
- Ratio: 6.142 : 1
- Hypoid type ring gear 292 mm diameter
- Load sensing proportioning valve
- Oil capacity: 3.0 litres
- Limited slip diff

REAR SUSPENSION

- Semi-elliptical, alloy steel, tapered, multi-leaf springs
- Hydraulic, double acting, telescopic, shock absorbers

FRONT AXLE - CAPACITY 2,800 KG

- Banjo full floating type with "Birfield" joints
- Axle ratio: 6.142 : 1
- Hypoid type ring gear 244 mm diameter
- Manual freewheeling hubs
- Oil capacity: 2.7 litres

FRONT SUSPENSION

- Semi-elliptical, alloy steel, tapered, multi-leaf springs
- Front anti roll stabiliser
- Hydraulic, double acting, telescopic, shock absorbers

STEERING

- Fully integrated power assisted recirculating ball type
- Gear ratio: 21.9 : 1
- Turns lock to lock: 5.0
- Steering wheel diameter: 410 mm
- Tilt/telescopic steering column

BRAKES

- Hydraulic dual circuit vacuum assisted tandem master
- Front - two leading shoes
- Rear - dual two leading shoes
- Drum diameter front and rear: 320 mm
- Total lining area: 1,840 sq cm
- Total swept area: 6,032 sq cm
- Transmission mounted internal expanding park brake
- Auxiliary exhaust brake

CHASSIS FRAME

- Rolled steel ladder type channel section with cold riveted crossmembers
- Sidemember dimensions: 203 x 65 x 6 mm
- Width across chassis: 750 mm

WHEELS AND TYRES

- Two piece rim and pressed steel disc, 6.0 GS x 16 with 127 mm offset, 6 stud, 20 mm bolt size
- Tyres: 7.50 x 16 - 10 ply tube tyres, single front, dual rear
- Spare wheel supplied on chassis
- Number of tyres - including spare: 7

ELECTRICAL SYSTEM

- 24 volt negative earth system with fuse protection for all major circuits
- Battery: 2 x 12 volt, 60 amp/hour
- Alternator: 24 volt, 40 amp with voltage regulator

CAB EXTERIOR

- Forward control, all steel, cab over engine
- Integrally welded one piece structure
- Cab suspended at front on neoprene bushes
- Cab tiltable to 45° with torsion bar assistance
- Curved and tinted windshield
- Large exterior "Aero" type mirrors, with underview mirror on passenger side
- Large aluminium drain board steps
- Front mud flaps
- Double action door hinges opening to 90°
- Low viewing window in LH passenger door
- Cab finished in "Arc White" enamel paint

CAB INTERIOR

- Deluxe trim with sound insulation
- Vinyl floor mat
- Adjustable highback reclining driver's seat
- Double passenger seat with hinged cushion for interior engine access
- Centre seat fold down for built-in tray with clip board
- Door pockets
- Roof header tray
- Driver's sun visor
- Grab handles

- Cigarette lighter
- Rear view mirror
- Air conditioner with heater and defroster
- Full flow fresh air ventilation
- Dome lamp
- Glovebox
- Ashtray
- Digital clock
- AM/FM radio cassette
- Retractable lap/sash seat belts on outboard seats, lap belt on inboard seat
- Collapsible floor mounted gear lever
- Power windows
- Access to fluid checks without tilting cab
- Central door locking
- Roof vent
- Sliding drawer cup holder
- Centre console box

INSTRUMENTS AND CONTROLS

- Speedometer with digital odometer
- Tachometer
- Gauges for coolant temperature and fuel level
- Warning lamps on dash panel for oil pressure, battery charge, exhaust brake and low brake fluid
- Steering column mounted combination switch on RH side for turn signal indicators, headlamps & headlamp dip/high beam
- Steering column mounted switches on LH side for windscreen wipers, washers, and exhaust brake control
- Key operation for engine stop/start and steering wheel lock
- Dash mounted fast idle control
- Steering wheel mounted horn bar
- Dome lamp switch

LAMPS

- 4 Sealed beam halogen headlamps
- 2 fog lamps
- Front and rear combination park/flasher
- Rear combination tail, stop and flasher
- Reverse lamp
- Front cornering lamps

TOOLS

- General hand tools and 5 tonne jack

WARRANTY

Vehicle: 36 months/100,000km (whichever comes first)
Corrosion (Perforation): 36 months