

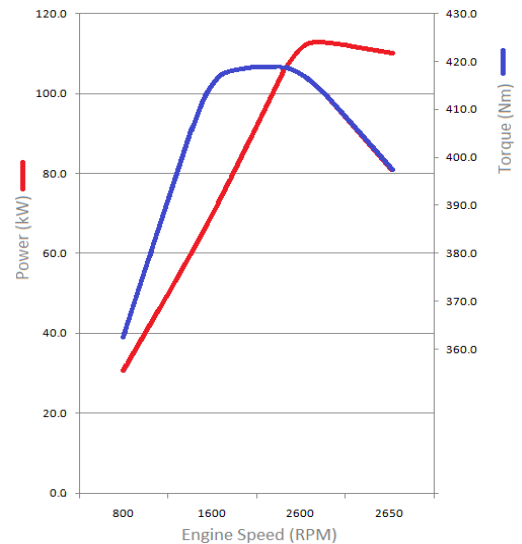

Model	NPR350 Tipper	NPR325 Tipper
GCM (kg)	10,000	9,495
GVM (kg)	6,500	5,995
Max Power (kW)	114	114
Wheelbase (mm)	3365	3365
Licence**	Class 2	Class 1

ENGINE

Engine Model:	4HK1-TCN
Type:	4 cyl 16 valve, SOHC
Displacement:	5,193 cc
Compression Ratio:	17.5:1
Max Power (DIN Nett):	114kW (155 HP) @2,600 RPM
Max Torque (DIN Nett):	419 Nm (309 lb.ft) @1,600 – 2600 RPM
Emission Control System:	Euro V with cooled EGR and Diesel Particulate Diffuser
Fuel System:	Electronically controlled direct injection, high pressure common rail 140 litre fuel tank with lockable fuel cap Water-in-fuel sensor standard
Air Intake System:	Electronically controlled variable nozzle turbo charger with air-to-air intercooler, vertical air intake behind cab



PERFORMANCE

- Maximum Towed Mass (braked): 3,500kgs - 1st Gear Gradeability @GVM: 325 40%/350 36%
- Maximum Towed Mass (unbraked): 2,000kgs - Est Engine RPM @90km/h :2085

TRANSMISSION

Manual	MYY6E 6spd manual, (standard) Synchronesh on 1 st to 6 th
Ratios (:1)	1 st 5.979, 2 nd 3.434 3 rd 1.862, 4 th 1.297, 5 th 1.000, 6 th 0.750, Rev 5.701
AMT:	MYY6E 6 spd Automated Manual with full automatic and sequential manual shift modes.
Ratios (:1)	1 st 5.979, 2 nd 3.434 3 rd 1.862, 4 th 1.297, 5 th 1.000, 6 th 0.750, Rev 5.701
PTO:	Provision on LHS of transmission case, countershaft driven wiring harness provided

AXLES

Front Axle:	Isuzu F031
Type:	Elliot reverse I-beam
Capacity:	3,100kgs
Rear Axle:	Isuzu RO66
Type:	Full floating banjo type housing
Capacity:	6,600kgs
Final Drive:	320mm diameter ring gear
Ratio (:1):	4.30

CHASSIS

Front Suspension

- Single stage alloy multi-leaf
- Double acting shock absorber
- Stabiliser bar

Steering

- Power assisted rack and pinion
- Turns lock-to-lock 5.4
- Gear Ratio 20.9:1

Chassis Frame

- Cold riveted ladder frame
- Rail dimensions (mm) 216 x70 x 4
- SAPH440 weldable steel

Rear Suspension

- MLS main, 1300x70x10 – 1, 1300x70x11 – 4
- Constant 175 N/mm
- TLS helper 850 x 70 x 9– 5, 850 x 70 x 8 - 1
- Combined constant 553 N/mm
- Double acting shock absorbers with stabiliser bar

Brakes

- Auto adjusting front discs, rear drums with hydraulic dual circuit control, vacuum assisted with Electronic Brake Distribution (EBD)
- ABS and ASR (traction control)
- Hill Start Aid (Except AMT)
- Front discs 293 x 40mm
- Rear drum 320mm x 100mm
- 190mm diameter drum park brake on rear of transmission
- Vacuum controlled exhaust brake

Wheels and Tyres

- 17.5 x 6.0 x 127mm 6-stud steel wheel rims
- 205/75R17.5 124/122M tubeless tyres
- Silver painted wheel rims
- Frame mounted spare wheel

Electrical

- 24 volt negative earth system
- 50 amp alternator
- Batteries - 2 x 80D26L 80Ah, 582CCA

CAB AND INTERIOR

CAB EXTERIOR

- All steel construction, high tensile steel on cab under-frame and side impact beam reinforcement
- Cab is fully compliant with ECE-R29 crash tests
- Manual cab tilt to 45° with torsion bar assistance
- Liquid filled front and rear cab mounts
- Heavy duty non-slip cab entry steps
- 70° opening doors
- Cab mounted main mirrors on front of cab
- Halogen multi-reflector headlamps with integral front turn signals
- Additional door mounted turn signals
- Polycarbonate front bumper with steel frame
- Combined brake/turn/reverse/marker lamps
- Registration plate lamps
- Reverse alarm buzzer standard

CAB INTERIOR

- Contoured adjustable driver's bucket seat with mechanical suspension rated to 130 kg
- Passenger bench seat with capacity for two adults
- Centre seat has lap belt
- 3-point ELR seatbelts in outboard seat positions

CAB INTERIOR (continued)

- Driver's seat belt has pre-tensioner SRS including air bag for driver and passenger
- Door and pillar entry assist grips both sides
- Lined interior, padded roof lining and vinyl floor covers
- RH and LH overhead storage shelf
- Height/reach adjustable steering column, soft-feel urethane steering wheel
- Electric windows
- Central locking with keyless entry and immobiliser
- Twin cup holders, 24V cigarette lighter
- Integrated air conditioning with 4 speed fan
- Door mounted storage pockets, LH glove box
- Multi Media radio/CD/DVD/MP3/WMA Player with 6.2" Touch Screen, Bluetooth, voice dialling, text to speech, SD and USB inputs, on-board recordable memory – optional external cameras with up to 4-way screen, GPS navigation and many other options
- Fluorescent interior light
- 5 DIN sized compartments for extra communications

INSTRUMENTS AND CONTROLS

- Key operated engine start/stop, steering lock
- HSA slow/fast engagement control with on/off switch (except AMT)
- ASR on/off switch
- DPD manual regenerate switch
- **LH combination stalk:** Windscreen wipers, washers and exhaust brake
- **RH combination stalk:** Indicators, light switch and headlamp dip switch, cruise control (AMT only)
- **Warning lamps:** Check engine, oil pressure, ABS, SRS, alternator charge, service brake, park brake on, seat belt unbuckled, AMT check
- **Interior Indicator lamps:** HSA, warm-up system, high beam, ASR, DPD status, 1st gear start, exhaust brake, turn signals

Tipper body:

- All-steel body with drop sides, auto release tailgate
- Auto release body lock-down hook
- Shovel rack, rope rails, non-slip side steps
- 20 second lift and lower time
- 3.0m³ bin volume
- Deck plate 3mm thick, all sides 2.3mm thick

WEIGHTS (kgs)

Model Codes	MODELS	RATINGS *		LOADING LIMITS (at ground)*		CHASSIS CAB TARE MASS **		
		GVM	GCM	FRONT	REAR	FRONT	REAR	TOTAL
NP2713	NPR325M Tipper	5995	9495	3100	6000	1960	1650	3610
NP2313	NPR350M Tipper	6500	10000	3100	6000	1980	1690	3670
NP3013	NPR325M AMT Tipper	5995	9495	3100	6000	1960	1650	3610
NP2913	NPR350M AMT Tipper	6500	10000	3100	6000	1980	1690	3670

* Vehicle ratings and front and rear mass limits are subject to regulatory requirements – Consult your dealer to select a specific vehicle to suit your requirements

** Chassis cab as supplied from the factory including 10 litres of fuel

DIMENSIONS (mm)

Models	WB	OAL	OAH *	CW	OAW	FOH	ROH	EA	CE	RT	ORT	FW	Kerb to Kerb (m)
NPR325 - 350M Tipper	3365	5970	2265	1995	2360	1110	1285	2680	4302	1650	2115	850	12.4

- Unladen weight

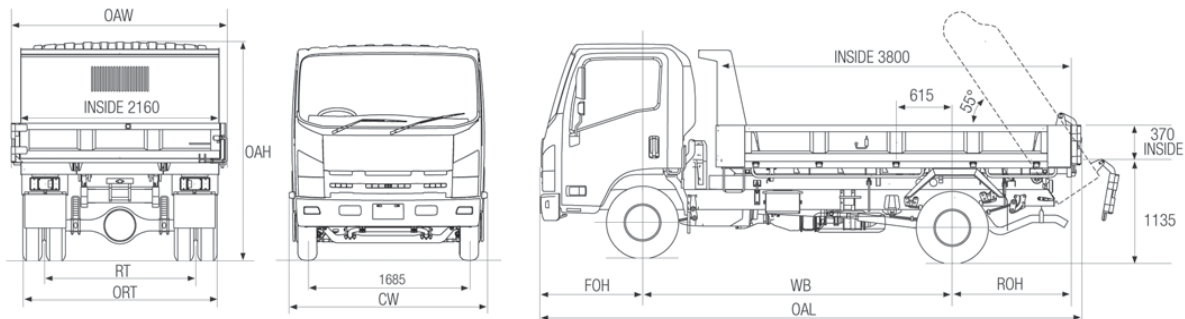

WARRANTY

Full vehicle warranty: 36 months or 100,000 kilometres whichever occurs first

All warranty is subject to terms and conditions as detailed in the Owner's Manual Service and Warranty Supplement

A policy of continuous improvement means that these specifications are subject to change without notice. Contact your Isuzu dealer or visit our website at Isuzu.co.nz to confirm specifications. Images of vehicles are representative only and may differ slightly from the actual vehicle

** Always refer to NZTA to confirm & for Licensing changes