

GVM - 5500kg
 GCM - 6800kg
 WHEELBASE - 3360mm

ISUZU 4HF1-II ENGINE PERFORMANCE

- Type: 4 Cylinder, in line, OHV, direct injection, four stroke, diesel
- Bore x Stroke: 112 x 110 mm
- Displacement: 4,334 cc
- Compression Ratio: 19.0:1
- Power Output: 76 kW @ 3,000 rpm
- Torque: 268 Nm @ 1,800 rpm

DIMENSIONS AND WEIGHTS

- Estimated Kerb Mass (kg):

Front	1,215
Rear	660
Total	1,875
- Frame Width: 700mm
- Turning Circle (m) (kerb to kerb): 14.6
- Ground Clearance (min): 200mm

TRANSMISSION

- Isuzu MXA5R - 5 speed overdrive with synchromesh on all forward gears.

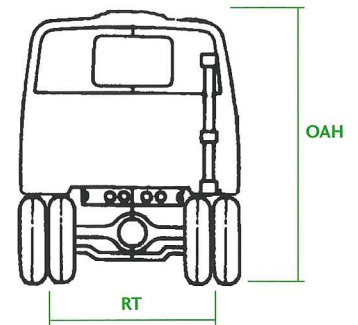
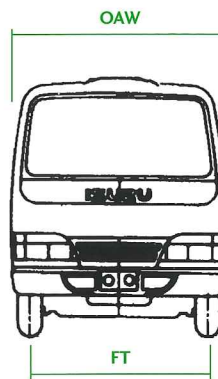
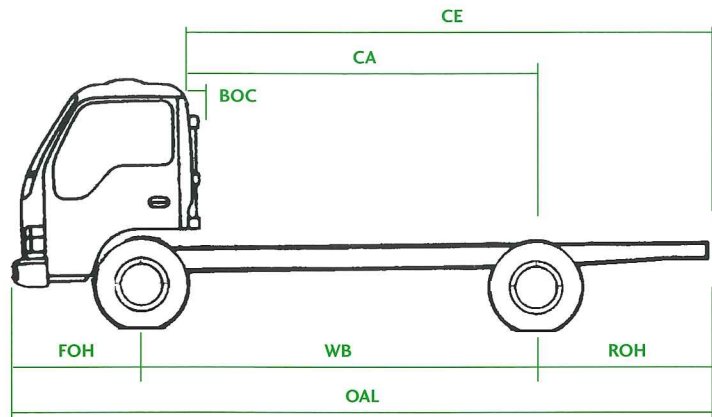

Wheelbase (WB)	3,360mm	Front overhang (FOH)	1,015mm
Cab to rear axle (CA)	2,810mm	Rear overhang (ROH)	1,455mm
Overall width (OAW)	1,695mm	Cab to rear of frame (CE)	4,265mm
Overall length (OAL)	5,830mm	Overall height (OAH)	2,120mm
Front Track (FT)	1,400mm	Back of cab/clearance (BOC)	95mm
Rear Track (RT)	1,425mm		

ENGINE - ISUZU 4HF1-II

Lubrication:

- Pressure feed lubrication with full flow paper element and partial flow sub filter
- Sump capacity: 8.5 litres including filter

Cooling System:

- Water cooled system thermostatically controlled with pressure vented heavy duty radiator
- V-Belt driven water pump with 400 mm diameter, 8 bladed, viscous hub, clutch controlled fan
- Coolant capacity: 14.5 litres

FUEL SYSTEM

- 'Zexel' in-line fuel injection pump with 'Bosch' 4 hole injectors
- Mechanical fuel pump
- Paper element air cleaner with raised vertical air intake
- Fuel tank capacity: 100 litres

CLUTCH

- Hydraulic control, dry, single plate, with diaphragm spring, asbestos free clutch plate 300 mm diameter
- Lining area: 847 sq cm (both sides)
- Auto adjusting clutch cylinder

TRANSMISSION - ISUZU MXA5R

- 5 speed overdrive, synchromesh with floor mounted short-throw gear shift & remote linkage to gearbox

Gear ratios:1

1st 4.987

2nd 2.870

3rd 1.594

4th 1.000

5th 0.728

Reverse 4.774

- Reverse warning buzzer
- Power take-off provision on left hand side
- Maximum geared speed on standard tyres: 108 km/hour
- Calculated maximum rolling gradeability at manufacturer's GVM = 34%, GCM = 27%

REAR AXLE - CAPACITY 4,000 KG

- Isuzu heavy duty fully floating banjo type with hypoid single speed reduction
- Ratio: 5.571 : 1
- Hypoid type ring gear 292 mm diameter
- Oil capacity: 3.0 litres

REAR SUSPENSION

- Semi-elliptical, alloy steel, tapered, multi-leaf springs
- Hydraulic, double acting, telescopic, shock absorbers

FRONT AXLE - CAPACITY 2,500 KG

- Reverse Elliot "I" - beam type

FRONT SUSPENSION

- Semi-elliptical, alloy steel, tapered, multi-leaf springs
- Hydraulic, double acting, telescopic, shock absorbers

STEERING

- Fully integrated power assisted recirculating ball type
- Gear ratio: 22.6 : 1
- Turns lock to lock: 4.3
- Steering wheel diameter: 410 mm
- Tilt/telescopic steering column

BRAKES

- Hydraulic dual circuit vacuum assisted tandem master
- Front - two leading shoes
- Rear - dual two leading shoes
- Drum diameter front and rear: 300mm
- Total lining area: 1,752 sq cm
- Total swept area: 5,656 sq cm
- Transmission mounted internal expanding park brake
- Auxiliary exhaust brake

CHASSIS FRAME

- Rolled steel ladder type channel section with cold riveted crossmembers
- Sidemember dimensions: 170 x 50 x 4.5 mm
- Width across chassis: 700mm

WHEELS AND TYRES

- One piece rim, 5.50F x 16 with 116.5 mm offset, 5 stud, 16 mm bolt size
- Tyres: 195/85R16 - tubeless tyres, single front, dual rear
- Spare wheel supplied on chassis
- Number of tyres - including spare: 7

ELECTRICAL SYSTEM

- 24 volt negative earth system with fuse protection for all major circuits
- Battery: 2 x 12 volt, 60 amp/hour
- Alternator: 24 volt, 50 amp with voltage regulator

CAB EXTERIOR

- Forward control, all steel, cab over engine
- Integrally welded one piece structure
- Cab tiltable to 45° with torsion bar assistance
- Curved and tinted windshield - laminated
- Triple wash jets - each wiper arm
- Large exterior "Aero" type mirrors, with underview mirror on passenger side
- Large aluminium drain board steps
- Front mud flaps
- Double action door hinges opening to 90°
- Cab finished in "Arc White" enamel paint

CAB INTERIOR

- Deluxe trim with sound insulation
- Vinyl floor mat
- Adjustable highback reclining driver's seat
- Double passenger seat with hinged cushion for interior engine access
- Door pockets
- Sun visors
- Grab handles
- Seat Belts
- Cigarette lighter
- Rear view mirror
- Heater and defroster

- Full flow fresh air ventilation
- Dome lamp
- Glovebox
- Ashtray
- AM/FM radio cassette with clock
- Floor mounted gear lever
- Passenger car style park brake control
- Access to fluid checks without tilting cab
- Sliding drawer cup holder

INSTRUMENTS AND CONTROLS

- Speedometer with digital odometer
- Tachometer
- Gauges for coolant temperature and fuel level
- Warning lamps on dash panel for oil pressure, battery charge, exhaust brake and low brake fluid
- Steering column mounted combination switch on RH side for turn signal indicators, headlamps & headlamp dip/high beam
- Steering column mounted switches on LH side for windscreen wipers, washers, and exhaust brake control
- Key operation for engine stop/start and steering wheel lock
- Dash mounted fast idle control
- Steering wheel mounted horn bar
- Dome lamp switch

LAMPS

- 4 halogen bulb headlamps
- Front and rear combination park/flasher
- Rear combination tail, stop and flasher
- Reverse lamp
- Front cornering lamps

TOOLS

- General hand tools and 4 tonne jack

WARRANTY

Vehicle: 36 months/100,000km (whichever comes first)

Corrosion (Perforation): 36 months